



## ISO 15488 (DIN 6499) System ER

Collet chucks for collets ISO 15488 (DIN 6499) ER-system

Mandrins à pinces pour pinces ISO 15488 (DIN 6499) système ER

**Verwendung:**

Zur Aufnahme von Werkzeugen mit Zylinderschaft in Spannzangen.

**Application:**

For mounting straight-shank tools in collets.

**Application:**

Destiné à recevoir les outils avec les queues de forme cylindrique dans les pinces de serrage.

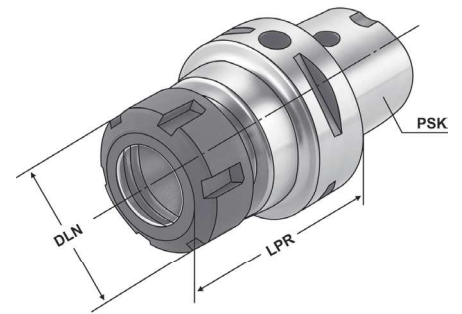

Bestell-Nr. Order no. Référence	PSK	DCONWS Spannbereich Capacity   Capacité	Typ	LPR	DLN	THID
C3.02.10	C3	1 - 10	426E   ER 16	45	32	-
C3.02.13	C3	2 - 13	428E   ER 20	45	34	-
C4.02.10	C4	1 - 10	426E   ER 16	70	32	-
C4.02.13	C4	2 - 13	428E   ER 20	52	34	-
C4.02.16	C4	2 - 16	430E   ER 25	52	42	-
C4.02.20	C4	2 - 20	470E   ER 32	54	50	-
C5.02.10.1	C5	1 - 10	426E   ER 16	100	32	M10x1
C5.02.13	C5	2 - 13	428E   ER 20	55	34	-
C5.02.13.1	C5	2 - 13	428E   ER 20	100	34	M10x1
C5.02.16	C5	2 - 16	430E   ER 25	55	42	-
C5.02.20	C5	2 - 20	470E   ER 32	57	50	-
C5.02.20.1	C5	2 - 20	470E   ER 32	100	50	M10x1
C6.02.10	C6	1 - 10	426E   ER 16	60	32	-
C6.02.16	C6	2 - 16	430E   ER 25	60	42	-
C6.02.20	C6	2 - 20	470E   ER 32	70	50	-
C6.02.26	C6	3 - 26	472E   ER 40	65	63	-
C6.02.10.1	C6	1 - 10	426E   ER 16	100	32	M10x1
C6.02.16.1	C6	2 - 16	430E   ER 25	100	42	M10x1
C6.02.20.1	C6	2 - 20	470E   ER 32	100	50	M10x1
C6.02.26.1	C6	3 - 26	472E   ER 40	100	63	M10x1
C6.02.10.130	C6	1 - 10	426E   ER 16	130	32	M10x1
C6.02.16.130	C6	2 - 16	430E   ER 25	130	42	M10x1
C6.02.20.130	C6	2 - 20	470E   ER 32	130	50	M10x1
C6.02.26.130	C6	3 - 26	472E   ER 40	130	63	M10x1
C6.02.10.160	C6	1 - 10	426E   ER 16	160	32	M10x1
C6.02.16.160	C6	2 - 16	430E   ER 25	160	42	M10x1

**Lieferumfang:** Mit gewuchteter Spannmutter  
**Delivery:** With balanced clamping nut  
**Livraison:** Avec écrou de serrage équilibré

